

GLASS PONY

Upstage

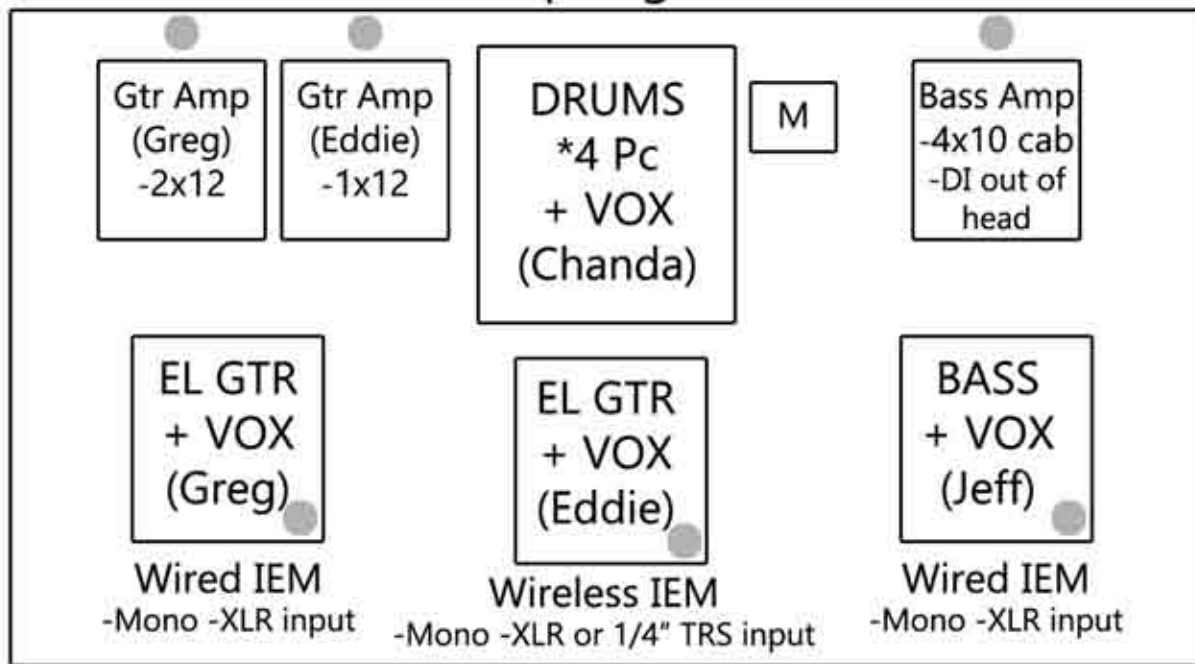

● = Power

Downstage

- 1- Kick *Shure Beta 52a
- 2- Snare *Sennheiser e604 or Shure SM57
- 3- Rack Tom *Sennheiser e604
- 4- Floor Tom *Sennheiser e604
- 5- OH L *Shure SM81
- 6- OH R *Shure SM81
- 7- Bass (DI)
- 8- Greg Gtr Amp (SR) *Sennheiser e906
- 9- Eddie Gtr Amp (SC) *Sennheiser e906
- 10- Greg Vox (SR) *Sennheiser e835
- 11- Eddie Vox (SC) *Telefunken M80
- 12- Jeff Vox (SL) *EV Cobalt Co9
- 13- Chanda Vox (Drums) *Shure Beta 57a

*We can provide all mics listed if requested

-Please let us know ahead of time,
we do not always carry drum mics

*We prefer to use our own vocal mics

*Venue provides stands/cables

Monitors

-We carry our own IEM rack with mixer (MR18) and 16 channel CBI analog splitter. We prefer to use this system for our IEM's. If this works for the audio tech we will provide a 25 ft. XLR tail from our split with ends clearly labeled by instrument to patch into the FOH snake. In this case Greg, Eddie and Jeff will mix themselves and we request a monitor for Chanda (Drums) that will be mixed by the FOH/Mon Engineer

-If this is not possible please let us know ahead of time and please provide 3 XLR returns downstage
-If applicable, we are happy to leave splitter on stage for duration of show

*For tech inquiries please contact Eddie at
GlassPonyBand@gmail.com or (518)698-9300

